

Pulling Solutions



 Sykes-Pickavant.

 SKF

 Beta

 FACOM

Pro for life



Mechanical Pullers

800 Series - Two Leg Mechanical Pullers

| Part No | Spread | | Reach | | Screw mm | Type of Leg |
|----------|--------|-----|-------|-----|-------------|-----------------|
| | ins | mm | ins | mm | | |
| 08300000 | 6 | 150 | 3.1/4 | 80 | 12 x 150 | Double Ended |
| 08310000 | 8 | 200 | 5.1/2 | 140 | 16 x 235 | Double Ended |
| 08320000 | 12 | 300 | 10 | 250 | 24 x 300 | Adj. 2 Position |
| 08330000 | 14 | 350 | 15 | 380 | 24 x 300 | Adj. 3 Position |



800 Series - Three Leg Mechanical Pullers

| Part No | Spread | | Reach | | Screw mm | Type of Leg |
|----------|--------|-----|-------|-----|-------------|-----------------|
| | ins | mm | ins | mm | | |
| 08270000 | 6 | 150 | 3.1/4 | 80 | 12 x 150 | Double Ended |
| 08280000 | 8 | 200 | 5.1/2 | 140 | 16 x 235 | Double Ended |
| 08290000 | 12 | 300 | 10 | 250 | 24 x 300 | Adj. 2 Position |
| 08340000 | 14 | 350 | 15 | 380 | 24 x 300 | Adj. 3 Position |



800 Series - Combination Two / Three Leg Pullers

| Part No | Spread | | Reach | | Screw mm | Type of Leg |
|----------|--------|---------|-------|--------|-------------|-----------------|
| | ins | mm | ins | mm | | |
| 08230000 | 2.1/2 | 60 | 2 | 50 | | Adj. 2 Position |
| 08270500 | 6 | 150 | 3.1/4 | 80 | 12 x 150 | Double Ended |
| 08280500 | 8 | 200 | 5.1/2 | 140 | 16 x 235 | Double Ended |
| 08490300 | 6/8 | 150/200 | 3/5 | 80/140 | 16 x 235 | Double Ended |



08490000 - Mechanical Gear Puller Set

Contains component parts to make 4 separate 2 / 3 leg pullers, as per table below...

| Part No | Spread | | Reach | | Screw mm | Type of Leg |
|----------|--------|-----|-------|-----|-------------|--------------|
| | ins | mm | ins | mm | | |
| 08300000 | 6 | 150 | 3.1/4 | 80 | 12 x 150 | Double Ended |
| 08270000 | 6 | 150 | 3.1/4 | 80 | 12 x 150 | Double Ended |
| 08310000 | 8 | 200 | 5.1/2 | 140 | 16 x 235 | Double Ended |
| 08280000 | 8 | 200 | 5.1/2 | 140 | 16 x 235 | Double Ended |



Mechanical Pullers



Concentric Easy Pullers

These pullers feature a Screw operated “concentric” action, and self adjusting leg. The self centering and self adjusting action makes it easy to position the puller with one hand whilst adjusting the force screw with the other. Once the legs are in position, the jaws are locked which eliminates the risk of slippage under load. These can be used as either a 2 or 3 leg puller.

| Part No | Capacity | Spread mm | Reach mm | Weight Kg |
|----------|-----------|-----------|----------|-----------|
| 10011000 | 2 tonnes | 120 | 80 | 1.6 |
| 10012000 | 3 tonnes | 140 | 90 | 2.3 |
| 10013000 | 5 tonnes | 270 | 160 | 4.3 |
| 10014000 | 8 tonnes | 300 | 210 | 6.1 |
| 10015000 | 10 tonnes | 380 | 250 | 9.6 |

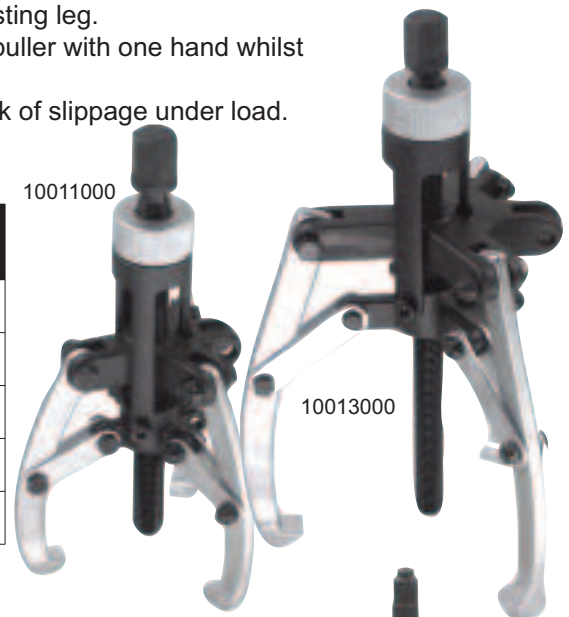

Self Grip Adjustable Pullers

- Light Duty, quick and simple to use
- Spring Loaded with self gripping legs
- Self centering action
- Easily adjustable for 3 leg format

| Part No | Capacity | Spread mm | Reach mm | Weight Kg |
|----------|------------|-----------|----------|-----------|
| 10031000 | 1.1 tonnes | 80 | 90 | 0.65 |
| 10032000 | 1.1 tonnes | 150 | 150 | 0.67 |
| 10033000 | 1.7 tonnes | 200 | 200 | 1.50 |



Auto Grip Adjustable Pullers

- Medium Duty, quick and simple to use
- Spring Loaded locking mechanism
- Automatic self gripping legs & Self centring action
- Can be used as either 2 or 3 Leg
- Safety shear to prevent overload

| Part No | Capacity | Spread mm | Reach mm | Weight Kg |
|----------|----------|-----------|----------|-----------|
| 10041000 | 3 tonnes | 140 | 150 | 1.6 |



Auto Grip Adjustable Pullers

- Three leg, fast fit puller, for rapid removal of small bearings
- Self centring screw with T-bar and hex drive
- Spring loaded legs for quick secure location
- Adjustable collar tightens under load for positiv, non-slip action

| Part No | Capacity | Min Spread mm | Max Spread mm | Reach mm |
|----------|----------|---------------|---------------|----------|
| 08215000 | 1 tonnes | 19 | 45 | 73 |





Mechanical Thin Jaw Pullers

860 Series - Two Leg Thin Jaw Manual Pullers

| Part No | Spread | | Reach | | Force Screw |
|----------|--------|-----|-------|-----|-------------|
| | ins | mm | ins | mm | |
| 08600000 | 3 | 75 | 3 | 75 | 12 x 150 |
| 08600200 | 3 | 75 | 5 | 125 | 12 x 150 |
| 08610000 | 6 | 150 | 6 | 150 | 24 x 225 |
| 08620000 | 9 | 225 | 9 | 225 | 24 x 300 |
| 08630000 | 6 | 150 | 9 | 225 | 24 x 300 |



860 Series - Three Leg Thin Jaw Manual Pullers

| Part No | Spread | | Reach | | Force Screw |
|----------|--------|-----|-------|-----|-------------|
| | ins | mm | ins | mm | |
| 08601000 | 3 | 75 | 3 | 75 | 12 x 150 |
| 08603000 | 3 | 75 | 5 | 125 | 12 x 150 |
| 08640000 | 6 | 150 | 6 | 150 | 24 x 225 |
| 08650000 | 9 | 225 | 9 | 225 | 24 x 300 |

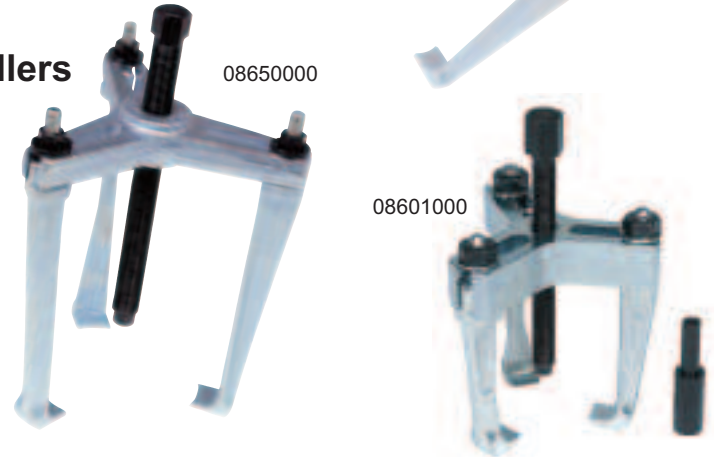

860 Series - Combination Two / Three Leg Puller

| Part No | Spread | | Reach | | Force Screw |
|----------|--------|----|-------|--------|-------------|
| | ins | mm | ins | mm | |
| 08600300 | 3 | 75 | 3/5 | 75/125 | 12 x 150 |



09300500 - Thin Jaw Separator Puller Set

Combination pack consisting of thin jaw puller and bearing separator, as per table below...

| Part No | Spread | | Reach | | Type of Leg |
|----------|----------|----|-------|----|--------------|
| | ins | mm | ins | mm | |
| 08600000 | 3 | 75 | 3 | 75 | Thin Jaw |
| | Capacity | | Reach | | |
| 09300000 | 2.1/4 | 55 | 4.1/2 | 55 | Pulling Rods |

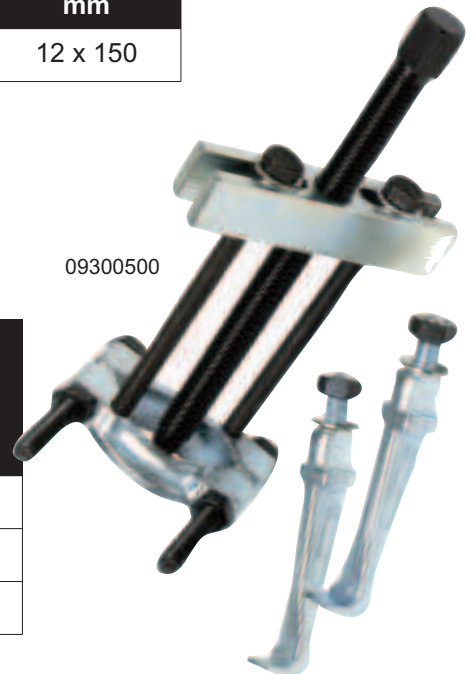

| Part No | Description | Spread mm | Reach mm |
|---------|-----------------|-----------|----------|
| 1500N/1 | Twin Leg Puller | 90mm | 100mm |
| 1500N/2 | Twin Leg Puller | 120mm | 100mm |
| 1500N/3 | Twin Leg Puller | 170mm | 150mm |
| 1500N/4 | Twin Leg Puller | 220mm | 150mm |
| 1500N/5 | Twin Leg Puller | 290mm | 205mm |
| 1500N/6 | Twin Leg Puller | 360mm | 205mm |

Internal Pullers



| Component | Spread mm | | Kit Reference | | | | |
|--------------------|-----------|------|-----------------------|-----------------------|------------------------|------------------------|-------------------------|
| | Min | Max | 09580000 6 - 60 mm | 09580100 6 - 13 mm | 09580200 13 - 30 mm | 09580300 30 - 60 mm | 09580400 8 - 22.5 mm |
| 09580900 Extractor | 6 | 8.5 | ✓ | ✓ | | | |
| 09581000 Extractor | 8 | 11 | ✓ | ✓ | | | ✓ |
| 09581100 Extractor | 10.5 | 13 | ✓ | ✓ | | | ✓ |
| 09581200 Extractor | 13 | 18 | ✓ | | ✓ | | ✓ |
| 09581300 Extractor | 18 | 22.5 | ✓ | | ✓ | | ✓ |
| 09581400 Extractor | 22.5 | 30 | ✓ | | ✓ | | |
| 09581500 Extractor | 30 | 38 | ✓ | | | ✓ | |
| 09581600 Extractor | 38 | 50 | ✓ | | | ✓ | |
| 09581700 Extractor | 50 | 60 | ✓ | | | ✓ | |
| 09582000 Extractor | - | - | ✓ | ✓ | ✓ | | ✓ |
| 09580500 Extractor | - | - | ✓ | | | | |
| 08542100 Extractor | - | - | ✓ | ✓ | ✓ | ✓ | ✓ |

09580000



09580100



09580200

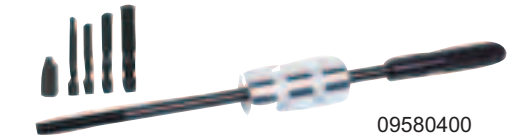

09580400

| Part No | Internal Capacity | Internal Capacity | Reach |
|----------|------------------------|--------------------|---|
| 08540000 | 3/4 - 4.1/4 (20-105mm) | 0 - 3 (0-75mm) | |
| 08545000 | 1/2 - 4.1/4 (13-105mm) | 0 - 2.1/2 (0-66mm) | Straight Leg - 75mm Cranked Leg - 65mm |



08545000



08540000

08540300 Combination Slide Hammer Puller Kit

- Slide Hammer
- 4 x Extractors 10.5 - 30mm
- 3 x Straight & 3 x Cranked Legs
- Adjustable Cone to Vary Internal / External option

| Part No | Internal Capacity | External Capacity |
|----------|-------------------|-------------------|
| 08540000 | 20 - 105 mm | 0 - 75mm |
| 09581100 | 10.5 - 13 mm | - |
| 09581200 | 13 - 18 mm | - |
| 09581300 | 18 - 22.5 mm | - |
| 09581400 | 22.5 - 30 mm | - |



08540300



Hydraulic Pullers

1500 Series - Two Leg Hydraulic Pullers

| Part No | Spread | | Reach | | Ext. Travel ins | Extension Ref |
|----------|--------|---------|-------|-----|--------------------|---------------|
| | ins | mm | ins | mm | | |
| 15240000 | 2-4 | 50-100 | 4 | 100 | 2 | 15242200 |
| 15260000 | 3-6 | 75-150 | 6 | 150 | 4 | 15262400 |
| 15270000 | 3-6 | 75-150 | 10 | 250 | 6 | 15272600 |
| 15280000 | 4-8 | 100-200 | 8 | 200 | 6 | 15272600 |
| 15290000 | 5-10 | 130-250 | 10 | 250 | 6 | 15272600 |



1500 Series - Three Leg Hydraulic Pullers

| Part No | Spread | | Reach | | Ext. Travel ins | Extension Ref |
|----------|--------|---------|-------|-----|--------------------|---------------|
| | ins | mm | ins | mm | | |
| 15340000 | 2-4 | 50-100 | 4 | 100 | 2 | 15242200 |
| 15360000 | 3-6 | 75-150 | 6 | 150 | 4 | 15262400 |
| 15370000 | 3-6 | 75-150 | 10 | 250 | 6 | 15272600 |
| 15380000 | 4-8 | 100-200 | 8 | 200 | 6 | 15272600 |
| 15390000 | 5-10 | 130-250 | 10 | 250 | 6 | 15272600 |



1500 Series - Combination Two/Three Leg Puller Kits

| Part No | Spread | | Reach | | Ext. Travel ins | Leg |
|----------|--------|--------|-------|---------|--------------------|----------------|
| | ins | mm | ins | mm | | |
| 15340500 | 2-4 | 50-100 | 4 | 100 | 2 | 4" 100mm |
| 15500300 | 2-6 | 50-150 | 4/6 | 100/150 | 2 / 4 | 4/6" 100/150mm |

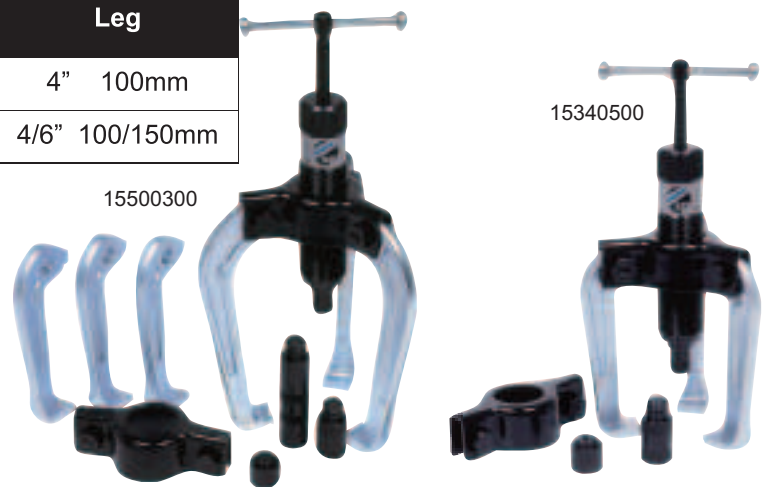

15000000 Hydraulic Ram

- A Grease filled ram, where pressure is applied through the T-Handle, creating forward thrust without twisting or distortion.
- Can be used with a wide variety of interchangeable SP Puller solutions
- Replacement Seal Kit & All replacement parts sold separately

Hydraulic Puller Kits



155000 - Hydraulic Puller Kit

Contains component parts to make 4 different 2 / 3 leg pullers, as per table below...

| Part No | Spread | | Reach | | Ext. Travel ins | No of Legs |
|----------|--------|--------|-------|-----|--------------------|------------|
| | ins | mm | ins | mm | | |
| 15240000 | 2-4 | 50-100 | 4 | 100 | 2 | 2 Leg |
| 15340000 | 2-4 | 50-100 | 4 | 100 | 2 | 3 Leg |
| 15260000 | 3-6 | 75-150 | 6 | 150 | 4 | 2 Leg |
| 15360000 | 3-6 | 75-150 | 6 | 150 | 4 | 3 Leg |



155200 - Hydraulic Puller & Separator Kit

Contains component parts to make 5 different pullers, as per table below...

| Part No | Spread | | Reach | | Ext. Travel ins | No of Legs |
|----------|-------------------------|--------|------------|-----|--------------------|------------|
| | ins | mm | ins | mm | | |
| 15240000 | 2-4 | 50-100 | 4 | 100 | 2 | 2 Leg |
| 15340000 | 2-4 | 50-100 | 4 | 100 | 2 | 3 Leg |
| 15260000 | 3-6 | 75-150 | 6 | 150 | 4 | 2 Leg |
| 15360000 | 3-6 | 75-150 | 6 | 150 | 4 | 3 Leg |
| | Separator Cap. | | Reach | | Rod Threads | |
| 19310000 | 3/4 - 4.1/4 20 - 105 | | 34.1/2 876 | | 1/2" BSF Separator | |



155400 - Hydraulic Puller & Separator Kit

Contains component parts to make 11 different pullers, as per table below...

| Part No | Spread | | Reach | | Ext. Travel ins | No of Legs |
|----------|-------------------------|---------|------------|-----|--------------------|------------|
| | ins | mm | ins | mm | | |
| 15240000 | 2-4 | 50-100 | 4 | 100 | 2 | 2 Leg |
| 15340000 | 2-4 | 50-100 | 4 | 100 | 2 | 3 Leg |
| 15260000 | 3-6 | 75-150 | 6 | 150 | 4 | 2 Leg |
| 15360000 | 3-6 | 75-150 | 6 | 150 | 4 | 3 Leg |
| 15270000 | 3-6 | 75-150 | 10 | 250 | 4 + 2 | 2 Leg |
| 15370000 | 3-6 | 75-150 | 10 | 250 | 4 + 2 | 3 Leg |
| 15280000 | 4-8 | 100-200 | 8 | 200 | 6 | 2 Leg |
| 15380000 | 4-8 | 100-200 | 8 | 200 | 6 | 3 Leg |
| 15290000 | 5-10 | 130-250 | 10 | 250 | 6 | 2 Leg |
| 15390000 | 5-10 | 130-250 | 10 | 250 | 6 | 3 Leg |
| | Separator Cap. | | Reach | | Rod Threads | |
| 19310000 | 3/4 - 4.1/4 20 - 105 | | 34.1/2 876 | | 1/2" BSF Separator | |



Quick reference - The maximum force exerted in tons should be 7 to 10 times the diameter of the shaft in inches (For example, a 2" diameter shaft would generally require a 20 tons puller)
Spray Bearing/Shaft with Penetrating oil and leave for 15 mins before pulling



Hydraulic Thin Jaw Pullers

1860 Series - Three Leg Hydraulic Pullers

| Part No | Spread | | Reach | | Ext. Travel ins |
|----------|--------|-----|-------|-----|--------------------|
| | ins | mm | ins | mm | |
| 18610000 | 6 | 150 | 6 | 150 | 15242200 - 2ins |
| 18620000 | 9 | 225 | 9 | 225 | 15272600 - 6ins |
| 18630000 | 6 | 150 | 9 | 225 | 15272600 - 6ins |

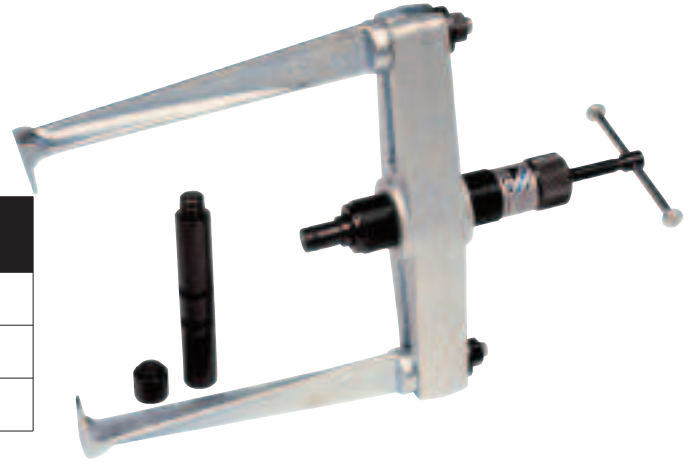

1860 Series - Three Leg Hydraulic Pullers

| Part No | Spread | | Reach | | Ext. Travel ins |
|----------|--------|-----|-------|-----|--------------------|
| | ins | mm | ins | mm | |
| 18640000 | 6 | 150 | 6 | 150 | 15242200 - 2ins |
| 18650000 | 6 | 150 | 9 | 225 | 15272600 - 6ins |



186504 Hydraulic Thin Jaw Puller Kit

Contains component parts to make 7 separate 2 / 3 leg pullers, as per table below...

| Part No | Spread | | Reach | | Screw & Ext. | No of Leg |
|----------|--------|-----|-------|-----|--------------|-----------|
| | ins | mm | ins | mm | | |
| 08600000 | 3 | 75 | 3 | 75 | 12 x 150 | 2 Leg |
| 18610000 | 6 | 150 | 6 | 150 | 2 ins | 2 Leg |
| 18615000 | 9 | 225 | 6 | 150 | 2 ins | 2 Leg |
| 18620000 | 9 | 225 | 9 | 225 | 6 ins | 2 Leg |
| 18630000 | 6 | 150 | 9 | 225 | 6 ins | 2 Leg |
| 18640000 | 6 | 150 | 6 | 150 | 2 ins | 3 Leg |
| 18650000 | 6 | 150 | 9 | 225 | 6 ins | 3 Leg |

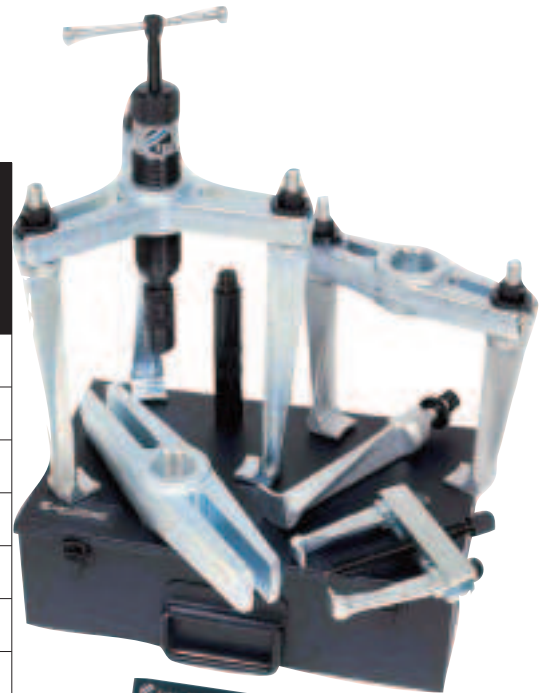

186505 Hydraulic Thin Jaw Puller Kit

Contents as per 186504 Puller Kit - but with Workshop Display Panel



Combination Puller Kits



19310500 Combination Separator & Extractor Kit

Contains component parts to make 8 different 2 / 3 leg pullers, as per table below...

| Part No | Spread | | Reach | | Type of Puller |
|----------|-----------------|-----|--------------|-----|-------------------|
| | ins | mm | ins | mm | |
| 08600000 | 3 | 75 | 3 | 75 | Thin Jaw |
| | Capacity | | Reach | | |
| 09300000 | 2 1/4" | 55 | 4 1/2" | 55 | Pulling Rods |
| 19310000 | 4 1/4" | 105 | 34 1/2" | 876 | Pulling Rods |
| 09580000 | 6mm - 38mm | | Slide Hammer | | 7 x Split Collets |



15510500 Hydraulic Puller Kit

Contains component parts to make 8 different 2 / 3 leg pullers, as per table below...

| Part No | Spread | | Reach | | Ext. Travel | No of Legs |
|----------|--------|---------|-------|-----|-------------|------------|
| | ins | mm | ins | mm | | |
| 15240000 | 2-4 | 50-100 | 4 | 100 | 2 | 2 Leg |
| 15340000 | 2-4 | 50-100 | 4 | 100 | 2 | 3 Leg |
| 15260000 | 3-6 | 75-150 | 6 | 150 | 4 | 2 Leg |
| 15360000 | 3-6 | 75-150 | 6 | 150 | 4 | 3 Leg |
| 15280000 | 4-8 | 100-200 | 8 | 200 | 6 | 2 Leg |
| 15380000 | 4-8 | 100-200 | 8 | 200 | 6 | 3 Leg |
| 15290000 | 5-10 | 130-250 | 10 | 250 | 6 | 2 Leg |
| 15390000 | 5-10 | 130-250 | 10 | 250 | 6 | 3 Leg |



15530500 Comprehensive Puller, Separator & Extractor Kit

- Combines the 19310500 and 15510500 to make the most comprehensive set of pulling, separating and extracting options available.

- Ideal Workshop Solution for applications where a wide variety of pulling and extracting problems are encountered on a regular basis

- Supplied on a Wall Mounted panel for ease of use and access

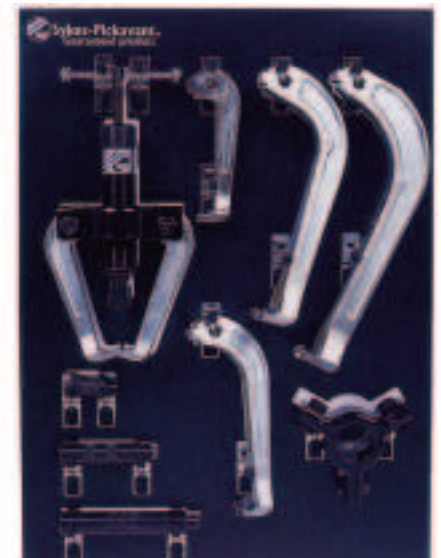



Specialist Pullers

09810000

098 Series - Blind Hole Pullers

| Part No | Ball End Diam. mm | Min Spread mm | Max Spread mm | Reach |
|--|-------------------|---------------|---------------|-------------|
| 09800000 | 5.5 - 8.0 | 20 | 95 | 125 |
| 09810000 | 5.5 - 12.5 | 20 | 117 | 415 |
| 09820000 | 16.0 - 31.75 | 56 | 210 | 490 |
| to suit following ISO Bearing Dimensions | | | | |
| 09800000 | 6004 - 6010 | 6200 - 6205 | 6300 - 6302 | |
| 09810000 | 6004 - 6015 | 6200 - 6211 | 6300 - 6307 | 6403 - 6404 |
| 09820000 | | 6212 - 6222 | 6308 - 6319 | 6405 - 6414 |











1547/C6 Dummy Ball Bearing Extractor

| | |
|--------|--|
| 1547/1 | 6004 - 6010, 6200 - 6205, 6300 - 6304 |
| 1547/2 | 6011 - 6014, 6206 - 6211, 6303 - 6308, 6403 - 6405 |



TMMD 100

TMMD 100 Blind Housing Puller

- Each claw is especially designed to facilitate a precise fit in the bearing's raceway, providing exceptional grip and allowing the application of higher dismounting forces.
- Each Puller arm is fitted with a spring to allow easy installation
- The Puller arms are made of a single piece, laser cut hardened steel for strength and longevity
- Does not require removal of the cage for use

Bearing Selection Table...

| DGBB Series | Spindle TMMD 100-S1 | | | | | Spindle TMMD 100-S2 | | | | | | |
|-------------|---------------------|------|-------|-------|-------|---------------------|------|------|------|------|------|------|
| | A1 | A2 | A3 | A4 | | A5 | | | A6 | | | |
| 60.. | 6000 | 6004 | 6007 | - | 6011 | - | 6014 | 6016 | 6018 | - | - | - |
| | 6001 | 6005 | 6008 | - | 6012 | - | 6015 | 6017 | 6019 | - | - | - |
| | 6002 | 6006 | 6009 | - | 6013 | - | - | - | 6020 | - | - | - |
| 62.. | 6200 | 6201 | 6204 | 6206 | - | 6207 | 6209 | 6210 | - | 6212 | 6214 | 6218 |
| | - | 6202 | 6205 | - | - | 6208 | - | 6211 | - | 6213 | 6215 | - |
| | - | 6203 | - | - | - | - | - | - | - | - | 6216 | - |
| | - | - | - | - | - | - | - | - | - | - | 6217 | - |
| 63.. | - | 6300 | 6301 | 6303 | - | 6305 | 6306 | 6307 | 6308 | - | 6309 | 6311 |
| | - | - | 6302 | 6304 | - | - | - | - | - | - | 6310 | 6312 |
| 62/.. | - | - | 62/22 | 62/28 | - | - | - | - | - | - | - | - |
| 63/.. | - | - | - | - | 63/22 | 63/28 | - | - | - | - | - | - |
| 64.. | - | - | - | - | - | - | 6403 | - | 6404 | 6406 | 6407 | 6408 |
| | - | - | - | - | - | - | - | - | 6405 | - | - | 6409 |
| 160.. | 16002 | - | 16011 | - | - | - | - | - | - | - | - | - |
| | 16003 | - | - | - | - | - | - | - | - | - | - | - |
| 161.. | 16100 | - | - | - | - | - | - | - | - | - | - | - |
| | 16101 | - | - | - | - | - | - | - | - | - | - | - |



Other Manual Pullers



08100000

Universal Bearing Ring Puller

- Ideal for removal of Taper Roller & Angular Contact Ball Bearing Raceways
- Removes the need for cutting tools
- Legs "cut" and are pressed into the radius behind the ring
- Loose / Tight pulling principle - force is applied evenly around the ring

08100000

U.306 Fast Fit Spring loaded Bearing Puller

| Part No | Spread mm | Reach mm | Max. Load | No of Legs |
|-----------|-----------|----------|-----------|------------|
| U.306A140 | 7-140 | 147 | 3T | 3 |
| U.306-180 | 10-180 | 200 | 4T | 3 |
| U.306-260 | 20-260 | 250 | 4T | 3 |

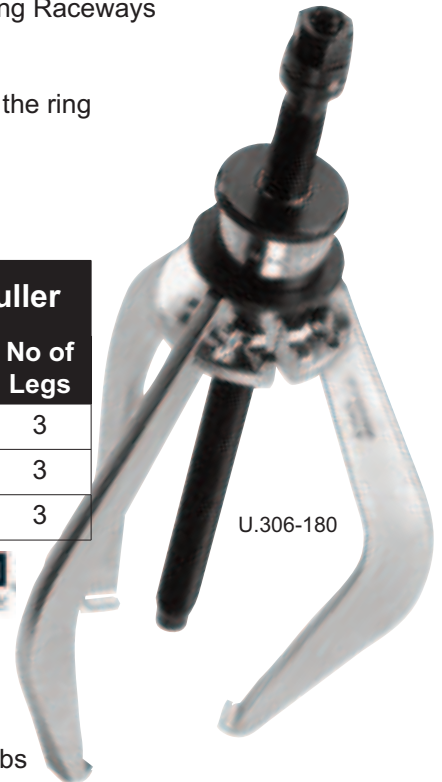

U.306-180



TMMX

Bearing Puller Protection Blanket

- Offers additional protection for end user during dismantling jobs
- The tough, transparent plastic allows the user to monitor the component and the puller during operation
- Suitable for the use in combination with many pullers
- Especially designed to fit SKF TMMMA Series Pullers



TMMMA Easy Pull Mechanical Pullers

| Part No | Spread mm | Reach mm | Max. Load | No of Legs |
|-----------|-----------|----------|-----------|------------|
| TMMMA 60 | 36 - 150 | 150 | 60 kN | 3 |
| TMMMA 80 | 52 - 200 | 200 | 80 kN | 3 |
| TMMMA 120 | 75 - 250 | 250 | 120 kN | 3 |

TMMP Standard Jaw Pullers

| Part No | Spread mm | Reach mm | Max. Load | No of Legs |
|--------------|-----------|----------|-----------|------------|
| TMMP 2 x 65 | 15 - 65 | 60 | 6 kN | 2 |
| TMMP 2 x 170 | 25 - 170 | 135 | 18 kN | 2 |
| TMMP 3 x 185 | 40 - 185 | 135 | 24 kN | 3 |
| TMMP 3 x 230 | 40 - 230 | 210 | 34 kN | 3 |
| TMMP 3 x 300 | 45 - 300 | 240 | 50 kN | 3 |





Loadstar “Lite” Puller Kits

Loadstar “Lite” is a new range of Medium Duty Hydraulic Pullers, featuring self-centring and self-locking puller legs.

The unique action of the twin-collar design produces increased grip as the load is increased, which is ideal for situations requiring one-man operation.

Loadstar “Lite” pullers can be used in either 2 leg or 3 leg formats, and feature 360° swivel hose couplings for optimum access with in-built safety valve to prevent overloading.

Loadstar “Lite” uses the same lightweight Aluminium Hydraulic pump, as the Loadstar “Plus” range, providing an economic solution for customers requiring Pulling solutions from 8 – 50 tonnes

20017000 - Aluminium Hand Pump 2 Speed, 10,000psi

Lightweight Aluminium bodied hand pump fitted with gauge, hydraulic hose and 3/4” hydraulic coupler. C/w Steel Storage Case.

20017000

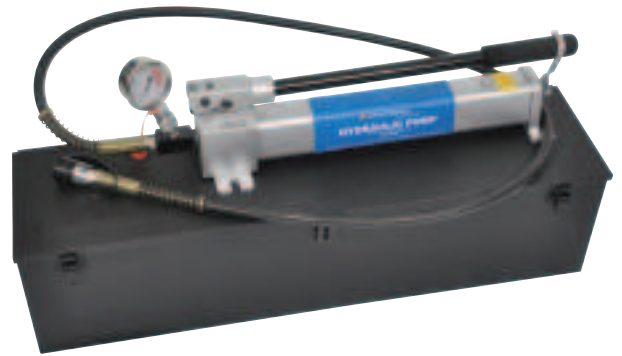

20100800



20100800 - 8 tonnes Loadstar “Lite” Puller Kit

| | |
|--|---|
| Aluminium Hydraulic Hand Pump 2 speed, 10,000psi | 1 |
| 8 tonne Hydraulic Easy Puller | 1 |
| Ram Extension Rods for increased stroke length | 3 |
| Plastic Moulded Storage Case for Puller | 1 |
| Steel Storage Case for Pump | 1 |
| Max Spread 450mm / Max Reach 280mm | |

20101200 - 12 tonnes Loadstar “Lite” Puller Kit

| | |
|--|---|
| Aluminium Hydraulic Hand Pump 2 speed, 10,000psi | 1 |
| 12 tonne Hydraulic Easy Puller | 1 |
| Ram Extension Rods for increased stroke length | 4 |
| Plastic Moulded Storage Case for Puller | 1 |
| Steel Storage Case for Pump | 1 |
| Max Spread 485mm / Max Reach 305mm | |

20101200



20102000



20102000 - 20 tonnes Loadstar “Lite” Puller Kit

| | |
|--|---|
| Aluminium Hydraulic Hand Pump 2 speed, 10,000psi | 1 |
| 20 tonne Hydraulic Easy Puller | 1 |
| Ram Extension Rods for increased stroke length | 4 |
| Steel Storage Case for Puller | 1 |
| Steel Storage Case for Pump | 1 |
| Max Spread 570mm / Max Reach 365mm | |

20T Loadstar "Plus" Puller Kits



20200000 - 20 Tonne Loadstar "Plus" Puller Kit

Basic 20 tonne 3 leg Puller Kit, with both straight and cranked leg options, plus leg extensions for added reach

| | |
|--|---|
| Aluminium Hydraulic Hand Pump 2 speed, 10,000psi | 1 |
| 20 tonne Hydraulic Cylinder | 1 |
| 20 tonne 3-Way Beam c/w pins & nuts | 1 |
| Cranked Heavy Duty Puller Legs -380mm | 3 |
| Straight Heavy Duty Puller Legs – 200mm | 3 |
| Puller Leg Extensions c/w pins & nuts – 380mm | 3 |
| Heavy Duty Steel Storage Case | 1 |
| Max Spread 530mm / Max Reach 760mm | |

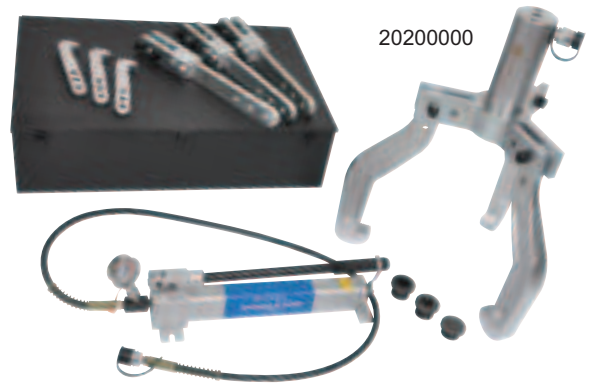

20202000 - 20 Tonne Loadstar "Plus" Separator Add-On Pack

Provides additional components to add Bearing Separator capability to basic 3 leg Puller Kit

| | |
|--|---|
| Bearing Separator 50 – 175mm (2" – 7") | 1 |
| 20 Tonne Twin Pulling Beam | 1 |
| Rod Assemblies | 2 |
| Steel Storage Case | 1 |
| Max Reach 420mm | |

20204000 - 20 Tonne Loadstar "Plus" Press Frame Add-On Pack

Press Frame assembly and accessories, providing portable press capability, to add to the basic 3 leg Puller Kit

| | |
|--------------------------------------|---|
| Press Frame – capacity 450mm x 165mm | 1 |
| Auto Grip Collar & Adaptor | 1 |
| Extractor / Pushing Pin 18mm x 75mm | 1 |
| Extractor / Pushing Pin 20mm x 150mm | 1 |
| Extractor / Pushing Pin 25mm x 150mm | 1 |
| Extractor / Pushing Pin 38mm x 150mm | 1 |
| Extractor / Pushing Pin 50mm x 150mm | 1 |
| Steel Storage Case | 1 |

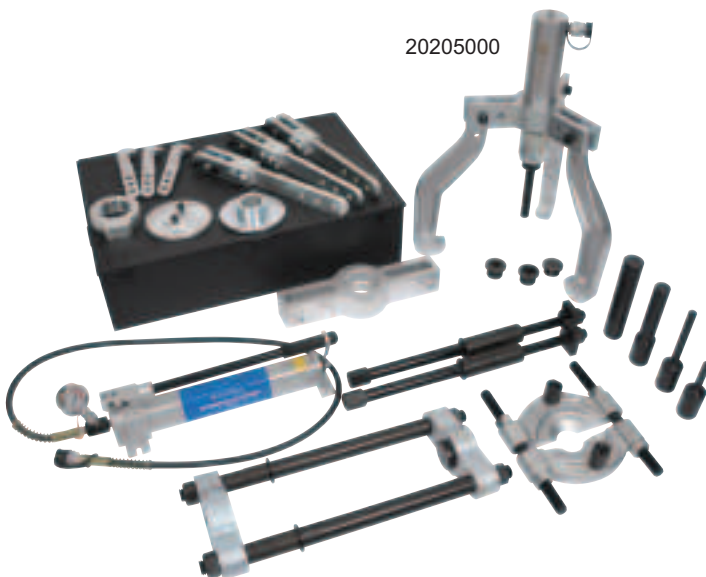
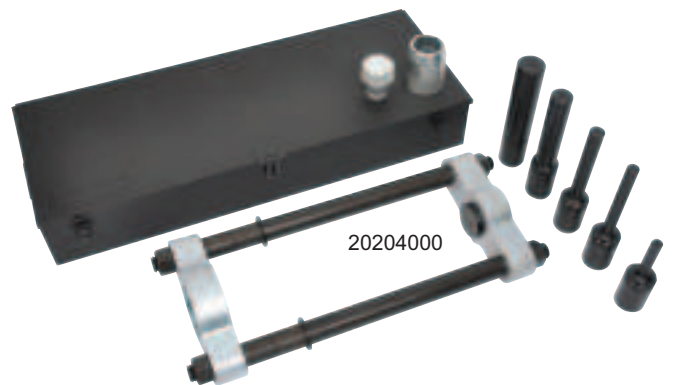

20205000 - 20 Tonne Loadstar "Plus" Comp. Puller Kit

Comprehensive 20 tonne Heavy Duty Puller Kit – with the addition of Bearing Separator, Press Frame and Extracting (Pushing) accessories

| | |
|---|---|
| Aluminium Hydraulic Hand Pump 2 speed, 10,000psi | 1 |
| 20 tonne Hydraulic Cylinder | 1 |
| 20 tonne 3-Way Beam c/w pins & nuts | 1 |
| Cranked Heavy Duty Puller Legs – 380mm | 3 |
| Straight Heavy Duty Puller Legs – 200mm | 3 |
| Puller Leg Extensions c/w pins & nuts – 380mm | 3 |
| Bearing Separator 50 – 175mm (2" – 7") | 1 |
| Twin Pulling Beam | 1 |
| Rod Assemblies | 2 |
| Cylinder Base Plate | 1 |
| Cylinder Pushing Plate | 1 |
| Cylinder Toe Lift Plate | 1 |
| Auto Grip Collar & Adaptor | 1 |
| Extractor / Pushing Pin 18mm x 75mm, 20mm x 150mm, 25mm x 150mm, 38mm x 150mm, 50mm x 150mm | 1 |
| Press Frame – capacity 450mm x 165mm | 1 |
| Steel Storage Case | 2 |



30T Loadstar “Plus” Puller Kits

20300000

30 Tonne Loadstar “Plus” Puller Kit

Basic 30 tonne 3 leg Puller Kit, with both straight and cranked leg options, plus leg extensions for added reach

| | |
|--|---|
| Aluminium Hydraulic Hand Pump 2 speed, 10,000psi | 1 |
| 30 Tonne Aluminium Hollow Cylinder | 1 |
| 30 Tonne 3-Way Beam c/w pins & nuts | 1 |
| Cranked Heavy Duty Puller Legs – 380mm | 3 |
| Straight Heavy Duty Puller Legs – 200mm | 3 |
| Puller Leg Extensions c/w pins & nuts – 380mm | 3 |
| Adjustment Screw c/w Handle & Nose Piece | 1 |
| Steel Storage Case | 1 |
| Max Spread 530mm / Max Reach 580mm | |



20300000

20302000

30 Tonne Loadstar “Plus” Separator Add-On Pack

Provides additional components to add Bearing Separator capability to basic 3 leg Puller Kit

| | |
|--|---|
| Bearing Separator 50 – 175mm (2” – 7”) | 1 |
| 30 Tonne Twin Pulling Beam | 1 |
| Rod Assemblies & Extensions | 4 |
| Steel Storage Case | 1 |
| Max Reach 860mm | |



20302000

20305000

30 Tonne Loadstar “Plus” Comprehensive Puller Kit

Comprehensive 30 tonne Heavy Duty Puller Kit – with the addition of Bearing Separator, and Internal Pulling Unit

| | |
|--|---|
| Aluminium Hydraulic Hand Pump 2 speed, 10,000psi | 1 |
| 30 Tonne Aluminium Hollow Cylinder | 1 |
| 30 Tonne 3-Way Beam c/w pins & nuts | 1 |
| Cranked Heavy Duty Puller Legs – 380mm | 3 |
| Straight Heavy Duty Puller Legs – 200mm | 3 |
| Puller Leg Extensions c/w pins & nuts – 380mm | 3 |
| Adjustment Screw c/w Handle & Nose Piece | 1 |
| Bearing Separator 50 – 175mm (2” – 7”) | 1 |
| 30 Tonne Twin Pulling Beam | 1 |
| Rod Assemblies & Extensions | 4 |
| Internal Pulling Unit | 1 |
| Steel Storage Cases | 2 |
| Max Spread 530mm/Max Reach 580mm/Sep Reach 860mm | |



20305000

50T Loadstar “Plus” Puller Kits



20500000

50 Tonne Loadstar “Plus” Puller Kit

Basic 50 tonne 3 leg Puller Kit, with both straight and cranked leg options, plus leg extensions for added reach

| | |
|--|---|
| Aluminium Hydraulic Hand Pump 2 speed, 10,000psi | 1 |
| 50 Tonne Aluminium Hollow Cylinder | 1 |
| 50 Tonne 3-Way Beam c/w pins & nuts – 380mm | 1 |
| Cranked Heavy Duty Puller Legs – 200mm | 3 |
| Straight Heavy Duty Puller Legs – 380mm | 3 |
| Puller Leg Extensions c/w pins & nuts | 3 |
| Adjustment Screw c/w Handle & Nose Piece | 1 |
| Steel Storage Case | 1 |
| Max Spread 530mm / Max Reach 470mm | |



20500000

20502000

50 Tonne Loadstar “Plus” Separator Add-On Pack

Provides additional components to add Bearing Separator capability to basic 3 leg Puller Kit

| | |
|--|---|
| Bearing Separator 50 – 175mm (2” – 7”) | 1 |
| 50 Tonne Twin Pulling Beam | 1 |
| Rod Assemblies & Extensions | 4 |
| Steel Storage Case | 1 |
| Max Reach 750mm | |

205020000



20505000

50 Tonne Loadstar “Plus” Comprehensive Puller Kit

Comprehensive 50 tonne Heavy Duty Puller Kit – with the addition of Bearing Separator, and Internal Pulling Unit

| | |
|--|---|
| Aluminium Hydraulic Hand Pump 2 speed, 10,000psi | 1 |
| 50 Tonne Aluminium Hollow Cylinder | 1 |
| 50 Tonne 3-Way Beam c/w pins & nuts | 1 |
| Cranked Heavy Duty Puller Legs – 380mm | 3 |
| Straight Heavy Duty Puller Legs – 200mm | 3 |
| Puller Leg Extensions c/w pins & nuts – 380mm | 3 |
| Adjustment Screw c/w Handle & Nose Piece | 1 |
| Bearing Separator 50 – 175mm (2” – 7”) | 1 |
| 50 Tonne Twin Pulling Beam | 1 |
| Rod Assemblies & Extensions | 4 |
| Internal Pulling Unit | 1 |
| Steel Storage Cases | 2 |
| Max Spread 530mm/Max Reach 470mm/Sep Max Reach 750mm | |

20505000



 Beta



1548/C5

Internal Bearing Extractor Kit

Pulls from within the raceway of Deep Groove Ball Bearings

- | | |
|--------|---------------------------------------|
| 1548 | /1 - /2 - /3 - /4 - /5 |
| 1548G4 | /1 - /2 - /3 - /4 - /5 - /6 - /7 - /8 |

 Beta



1545/C5

Internal Bearing Extractor Kit

Pulls from within the bore diameter of the Bearing

Covers Internal Bearing Dimensions 9 - 30mm

- | | | | |
|--------|----------|--------|----------|
| 1544/1 | 9-12 mm | 1544/4 | 20-25 mm |
| 1544/2 | 13-17 mm | 1544/5 | 25-30 mm |
| 1544/3 | 16-21 mm | | |

 FACOM
Pro for life



U.33A
30 Tonne Hydraulic Jack

- Force 30 Tonnes
- Travel 5mm
- Shear Pin Rating 110Nm
- Length 260 mm
- Plunder 33mm Diameter
- Supplied with 2 Shims - 25 & 50
- 19mm Hexagonal Screw

Puller Safety starts with you....

- Make sure that the puller is in good condition and that the Forcing Screw is evenly lubricated
- Apply even pressure to the Forcing Screw and do not use Pneumatic Impact Wrenches
- Use a 3 leg puller solution if possible for better load distribution
- Position the legs so that the puller is straight in relation to the line of pull
- If possible cover the Puller to protect against any parts of the puller or component breaking away suddenly
- Never stand behind or beside a puller
- Always wear Eye Protection and Gloves when using a puller
- Do not grind the legs of a Puller to make them fit. Never alter the original design for any reason
- Do not heat the component as this can melt the seals in Hydraulic Pullers

All Pullers within are made to a very high specification, but care should be taken to ensure that they are used safely and in accordance with good workshop practice. Always follow instructions where provided.

Produced and distributed by **E. Fox (Engineers) Ltd.**

All Pullers within this brochure are available from **E. Fox (Engineers) Ltd.**

Tel. 01-4693500

Fax. 01-4693555

Email. sales@efox.ie

www.efox.ie

Every care has been taken to ensure the accuracy of the information contained in this publication but no liability can be accepted for any loss or damage whether direct, indirect or consequential arising out of the use of the information contained herein.